

# A network coding algorithm for sense awareness of internet of things

XIANGTIAN ZHENG<sup>1,2</sup>, HAITAO MA<sup>2</sup>, GUIWEN REN<sup>2</sup>,  
FENG YANG<sup>1</sup>, CE LI<sup>1</sup>

**Abstract.** WSN (Wireless Sensor Networks) is a part of particular case of mobile wireless network, which is provided with distinctive feature. The routing protocol of traditional wireless network is difficult to directly apply to WSN. High speed of node triggers dynamic changes of the networks topology, which leads to frequent communications link failures of WSN. Link reliability issue of high dynamic network has aroused wide public concern. Therefore, route reliability aiming at expressway WSN is analyzed, the evolving graph theory is expanded, EEGM (extended - evolving graph model) is established, and EEGM is adopted to obtain dynamic information of WSN topology so as to obtain the information of reliable routing in advance. On this basis, reliable routing protocol (EGRAODV) based on evolving graph theory is proposed. The simulations reveal that routing protocol proposed has improved in packet transmission rate, end-to-end transmission delay, routing requests ratio and number of link failures aspects compared to other similar protocol.

**Key words.** Evolving graph theory; Route reliability; Route; WSN.

## 1. Introduction

Many people are killed in traffic accidents every day, for this reason, the research of WSN (Vehicular ad hoc networks) has gained wide attention. Road accidents can be prevented by distributing road safety messages through WSN. Therefore, WSN is regarded as one of the most promising techniques applying to road nodes communication [1]. WSN is a kind of special form of MANETs (Mobile ad hoc networks) which may realize the communication among nodes. Each Nodes in network may receive, send and forward messages to other nodes. The Nodes may interact real-time traffic information using this kind of method, which will be helpful for users to drive safely. Unlike MANETs, WSN has unique properties such as high transmission

---

<sup>1</sup>School of Mechanical Electronic&Information Engineering, China University of Mining and Technology (Beijing), Beijing, China

<sup>2</sup>China Academy of Safety Science and Technology, Beijing, China

power, high computing power, high-speed mobile of node, predictability of movement and dynamic change of network topology etc [2]. Such properties have brought a challenge to deploy WSN, especially high-speed mobile of node and dynamic change of topology [3][4]. In WSN, Nodes is viewed as Vertices and communication link among nodes is viewed as edge, and graph theory is quoted to understand topological property of WSN. Literature [5][6] proposed that mobile information of dynamic network can be captured using evolving graph theory against predictable mobility mode, this achievement shows good performance in MANETs and delay-tolerant networks [7], however, evolving graph theory cannot be directly applied to WSN. Therefore, this article takes nodes on freeway as analytic target and assume it's driving with constant speed. On this basis, Reliable WSN routing protocol based on revolution of graph theory is proposed using WSN communication graph results from improved graph theory.

## 2. WSN reliability model

Nodes are always in high-speed driving on freeway, which brings lots of trouble of setting up reliable routing scheme. The performance of route are affected by many factors, for example, mobility model of Nodes and Nodes distribution are factors that affect route [16]. To establish accurate Nodes reliability model, first of all, mobility model and Nodes distribution properties are required to be determined. The determination of Nodes distribution is in favor of predicting time of duration of communication among nodes.

### 2.1. Nodes distribution

There are two methods to describe spatiotemporal transmission of traffic flow: macroscopic and microcosmic flow model, respectively. Macroscopic quantity of aggregation is used by macroscopic flow model to describe Nodes flow, such as traffic density  $p(x, t)$ , traffic flow  $q(x, t)$  and average speed  $v(x, t)$ .  $x$  is denoted as spatial position,  $t$  is denoted as time. Formula below [18] is adopted to get associated with these parameters.

$$d_m = \frac{1000}{\rho_{veh}} - l_m, \quad (1)$$

$$\tau_m = \frac{d_m}{v_m} = \frac{1}{v_m} \left( \frac{1000}{\rho_{veh}} - l_m \right), \quad (2)$$

$$q_m = \frac{1}{\tau_m}. \quad (3)$$

Where,  $d_m$  is denoted as mean distance (m) among nodes;  $\rho_{veh}$  is denoted as traffic density (Nodes number per kilometer);  $l_m$  is denoted as average length (m) of nodes;  $v_m$  is denoted as average speed (km/hr) of nodes;  $\tau_m$  is denoted as average time (s) of communication among nodes;  $q_m$  is denoted as average traffic flow (Nodes number per hour). Microcosmic flow model is to describe Nodes as an independent

individual, mainly includes parameters like accelerated speed, retarded velocity and surrounding flow of lane-changing response. As everyone knows, macroscopic flow model can be used for describing general traffic flow state as well as can be seen as individual Nodes [19]. Therefore, macroscopic flow model is selected in this article. Next, link reliability model is established using distribution of Nodes speed from a macroscopic perspective.

### 2.2. Link reliability model

Definition: link reliability means probability of continuous availability for the link between nodes over a period of time. Link  $l$  is established when two nodes are in time  $t$ . Reliability of link can be denoted as  $r(l)$  in time frame  $T_p$ :

$$r(l) = P \{link \text{ continue to be available until } t + T_p\}$$

To calculate link reliability, Nodes speed distribution shall be analyzed first. Assume that Nodes speed is submitted to normal distribution [20]. For speed  $\vartheta$ , probability density function of its speed is denoted by  $g(\vartheta)$  based on this assumption. Correspondingly,  $G(\vartheta)$  is denoted as probability density function.

$$g(\vartheta) = \frac{1}{\sigma\sqrt{2\pi}} \exp\left(-\frac{(\vartheta - \mu)^2}{2\sigma^2}\right), \quad (4)$$

$$G(\vartheta \leq V_0) = \int_0^{V_0} g(\vartheta)d\vartheta. \quad (5)$$

Where,  $\mu$  and  $\sigma^2$  are denoted as mean value and variance of speed, respectively [21]. Distance  $d$  between nodes can be calculated through relative speed of nodes. Assume that communication range of nodes is  $R$ . Therefore, probability density function of sustainable communication  $T$  can be denoted as:

$$f(T) = \frac{4R}{\sigma_{\Delta v}\sqrt{2\pi}} \frac{1}{T^2} \exp\left(-\frac{(2R/T - \mu_{\Delta v})^2}{2\sigma_{\Delta v}^2}\right), T \geq 0. \quad (6)$$

Where,  $\Delta v$  is denoted as relative speed of nodes.  $\mu_{\Delta v}$  and  $\sigma_{\Delta v}^2$  are mean value and variance of relative speed  $\Delta v$ , respectively.

Nodes  $i$  and  $j$  are formed as link  $l$  at the time of  $t$ , lifetime  $T_p$  of link can be denoted as:

$$T_p = \frac{R - L_{i,j}}{\Delta v_{i,j}}. \quad (7)$$

Where,  $L_{i,j}$  is denoted as Euclidean distance between Nodes  $i$  and  $j$ .

Reliability value  $r(l)$  of link  $l$  can be calculated integrating formula (6) and (7)

$$r(l) = \begin{cases} \int_t^{t+T_p} f(T) dT & \text{if } T_p > 0 \\ 0 & \text{otherwise} \end{cases} \quad (8)$$

### 2.3. Definition of route reliability

There might be multi-route  $\omega$  on source node  $s$  and destination node  $d$  in WSN. Each route is comprised of a series of links. Without loss of generality, for some specific route  $P$ , assume that it's comprised of  $k$  links:  $l_1 = (s, n_1)$ ,  $l_2 = (n_1, n_2)$ ,  $\dots$ ,  $l_k = (n_k, d)$ . According to formula 8, link reliability of each link  $l_m$  ( $m = 1, 2, \dots, k$ ) can be denoted as  $r(l_m)$ . Therefore, route reliability  $Re(P(s, d))$  of route  $P$  is:

$$Re(P(s, d)) = \prod_{m=1}^k r(l_m). \quad (9)$$

Assume that there is  $\omega$  pieces of route on source node  $s$  and destination node  $d$ .  $M(s, d) = \{P_1, P_2, \dots, P_\omega\}$  is used as route set of source node  $s$  and destination node  $d$ . The most reliable route must be selected as an channel of data forwarding when making route-decision, namely the route is selected according to formula (10):

$$\arg \max_{P \in M(s, d)} Re(P). \quad (10)$$

## 3. Evolving graph model of facing WSN

Current evolving graph theory cannot be directly applied to WSN. Because current evolving graph model leaves out of consideration of reliability of communication link. Current evolving graph theory is expanded to satisfy the demand of WSN. Real-time traffic information is integrated and reliable information of communication link are infused in EEGM.

For a specific graph  $G(V, E)$ , the subgraph of it is denoted by  $S_G = G_1(V_1, E_1)$ ,  $G_2(V_2, E_2)$ ,  $\dots$ ,  $G_\lambda(V_\lambda, E_\lambda)$ . Therefore,  $\cup_{i=1}^\lambda G_i = G$ . Evolving graph theory is to be denoted by  $\tilde{G} = (S_G, G)$ , where,  $V_{\tilde{G}}$  and  $E_{\tilde{G}}$  are denoted as set of  $\tilde{G}$  node and edge, respectively.

In  $\tilde{G}$ , assume that  $\Omega$  is denoted as route, namely  $\Omega = e_1, e_2, e_3, \dots, e_k$ ,  $e_i \in E_{\tilde{G}}$ .  $\Omega_\sigma = \sigma_1, \sigma_2, \sigma_3, \dots, \sigma_k$  is adopted,  $\sigma_i \in \tilde{T}$  is denoted as time ordinal of each edge of route  $\Omega$  traversal.  $\tilde{T}$  is denoted as time domain of graph theory.

There are three rules on how to select access in current evolving graph theory: foremost: arrive first; shortest: minimum hop; fastest: minimum transmission delay.

### 3.1. EEGM

EEGM proposed lays stress on communication diagram of WSN and reliability of communication link is taken into consideration. Figure 1 shows examples of EEGM being faced with highway at two time moments, as shown in figure 1. The nodes in diagram are denoted as driving Nodes on the highway. Unlike evolving graph theory,  $(t, r(e))$  mark is used to each edge in EEGM, of which  $t$  is denoted as present time,  $r(e) = r(l)$  is denoted as link reliability, which is calculated with formula (8).

In EEGM, if  $r(e) = 0$ , then such communication link is null and void. Assume

that  $Trav(e)$  is the function of if decision-making link  $e$  can be ergodic or not, as shown in formula (11):

$$Trav(e) = \begin{cases} \text{True,} & 0 < r(e) < 1 \\ \text{False,} & r(e) = 0 \end{cases} \quad (11)$$

Figure 1 (a) shows reliability value of each link when  $t = 0$ . The figure indicated that all links are available,  $Trav(e)=\text{True}$ . Figure 1 (b) shows reliability value of each link when  $t = 5$ . The reliability of link is transformed from figure (a) to figure (b). Notice that  $\{B, E\}$  and  $\{F, G\}$  are no longer available, because  $r(\{B, E\}) = r(\{F, G\}) = 0$  when  $t = 5$ .

In addition, new index is quoted and it's called journey reliability. The link of forwarding data is selected through such index. The most reliable journey is selected rather than the foremost, shortest and fastest link when the data is forwarding.

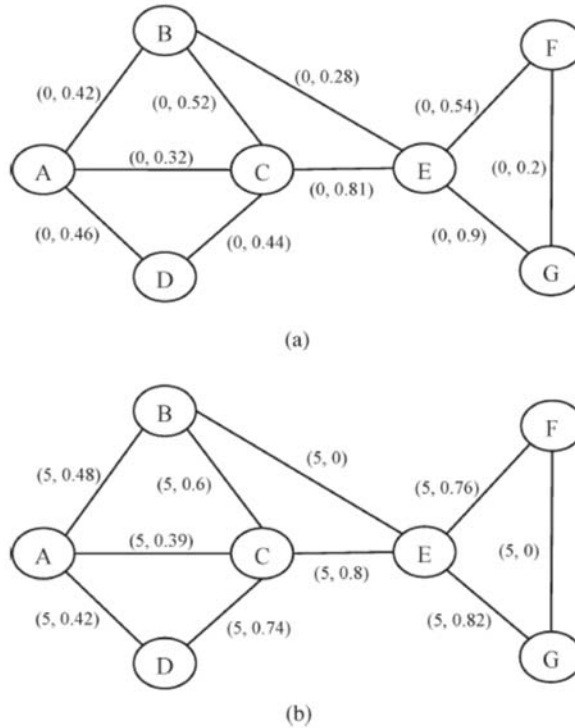

Fig. 1. EEGM model when  $t = 0$  and  $t = 5$

Assume that  $k$  edge integrates an available link  $J(i, j)$  which is from node  $i$  to node  $j$ . In time  $t$ , reliability value of edge  $e_w$  is denoted as  $r_t(e_w)$ . Therefore, reliability value  $Re(J(i, j))$  of the link as shown in formula (12).

$$Re(J(i, j)) = \prod_{w=1}^k r_t(e_w). \quad (12)$$

Assume that there are  $n$  links from node  $i$  to node  $j$ , the set of  $n$  links is denoted as  $MJ(i, j) = \{J_1, J_2, \dots, J_n\}$ , therefore, the most reliable link  $MJ(i, j) = \{J_1, J_2, \dots, J_n\}$  is selected through formula (13).

$$\arg \max_{J \in MJ(i, j)} Re(J) . \quad (13)$$

## 4. Mobility model

WSN scene which is investigated in this article is highway. Assume that nodes travel along with sole direction at constant speed. Such assumption is reasonable according to analysis of literature [11]. Based on such assumption, parameters below is set for each Nodes  $i$ ; Cartesian coordinates at time  $t$ :  $x_i(t)$  and  $y_i(t)$ ; speed  $v_i(t) = v_0$ ; moving direction  $a_i(t) = a_0$ .

## 5. EGRAODV proposed

To achieve an reliability of WSN data transmission, new routing protocol is proposed integrating properties of EEGM. Such routing protocol uses EEGM model to select an optimal route from source node to destination node from a perspective of reliability value of route. The most reliable MRJ scheme based on EEGM is selected, and this scheme is applied to AODV [22], the routing protocol proposed is denoted by EGRAODV.

### 5.1. EG-Dijkstra algorithm

To seek out the most reliable route in EEGM model is equivalent to find MRJ. Common Dijkstra algorithm [23] cannot be directly applied to this article, therefore, a modification shall be made, and Dijkstra algorithm based on evolving graph theory is proposed. EG-Dijkstra algorithm is employed to seek out MRJ based on formula (11) and (13).

EG-Dijkstra uses reliable graph to save all nodes and their corresponding MRJ value. In the initial stage of algorithm, source node  $s$  is  $RG(s) = 1$ , and the other node is  $RG(i) = \phi$ . Figure 2 gives a typical example of EG-Dijkstra algorithm.

Assume that source point is node 0 identified in figure 2, destination node is node 5, and  $RG(0) = 1$ . Reliability value  $r(l)$  of each link is calculated according to formula (8) calculation. If link reliability value between node 0 and node 1, then  $l_0 = (0, 1)$ . According to EG-Dijkstr algorithm, RG value of next node is gained using  $r(l_0)$  multiply by  $RG(0)$ . If node 0  $RG(1) = r(l_0) \times RG(0) = 1 \times 0.43 = 0.43$ . Node 5 is  $RG(5) = r(l_1) \times RG(1) = 0.43 \times 0.21 \approx 0.09$ , as shown in figure 2 (ii).

Although node 5 is destination node, EG-Dijkstra algorithm won't just stop at (ii), because it's required to calculate reliability value of all links and the most reliable value will be selected from them to be a route of data. Figure 3 shows that there are two ways to get to destination node: first  $0 \rightarrow 1 \rightarrow 5$ ; second  $0 \rightarrow 4 \rightarrow 2 \rightarrow 3 \rightarrow 6 \rightarrow 5$ . The reliability value of first link ( $0 \rightarrow 1 \rightarrow 5$ ) is 0.09, the second one is 0.13 as shown

in figure 3 (iv), which indicates that the second link is more reliable than the first one. Therefore, the second link is selected to be channel of data transmission.

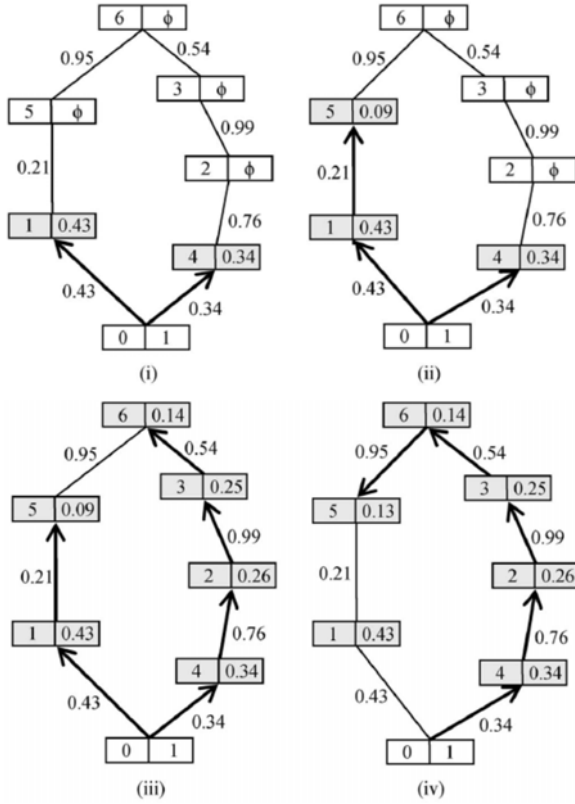

Fig. 2. Example of EGDijkstra algorithm

### 5.2. Properties of EGRAODV route

Assume that current EEGM's status information is known to source node. Resource node is required to transmit data at time  $t$ , it will first calculate reliability value of each link in EEGM model and EG- Dijkstra algorithm is used for seeking out the most reliable link MRJ. After attaining the most reliable MRJ, source node will perform RREQ (Routing request message), and hop count of MRJ will be added to RREQ, namely information of expanded RREQ and MRJ memory. Routing request will be forwarded from midside node without broadcast according to MRJ information.

The midside node is not required to send RREP (Routing reply message) to destination node when nodes with MRJ on the way received RREQ. There is a need to reply message to RREP only when RRED gets to destination node.

Above analysis indicated that there's no need for EGRAODV scheme to broadcast

routing request, which greatly saves up network resource. Moreover, EGRAODV doesn't use hello message to confirm the link condition, which reduces network loads. The mechanism, which is identical to AODV, is used by EGRAODV in the stage of route maintenance process. RERR (routing error message) will be sent out when the link is failed, thus achieving to maintain route and discover functions of new route.

## 6. Simulated analysis

The purpose of simulation lies in evaluating the performance of routing protocol proposed. OMNet++ is adopted to simulate. Each simulation experiment is conducted for 50 times and an average value of simulation is selected as final data. A comparison of simulation result is made with AODV and PBR.

### 6.1. Simulation environment

Simulation area is three-lane highway with an range of 5,000 meters. 30 nodes (traffic flow of low density) are distributed in simulation area. Nodes are only travelling to single direction and exit simulation area when it gets to the end of highway. Average speed of three lanes are 40, 60 and 80 km/h, respectively. A simulation is conducted aiming to two experimental scenes:

(1) Experiment A: rate of data signaling varies from 32 to 512 kb/s. The size of data package is 1500 bytes. Average Nodes speed on three lanes remain 40, 60 and 80 km/h.

(2) Experiment B: the size of data package varies from 500 to 3,000. Rate of data signaling is 128 kb/s. Average Nodes speed on three lanes remain 40, 60 and 80 km/h.

### 6.2. Performance index

Performance index below is adopted to evaluate network performance in simulation process.

(1) PDR (packet delivery ratio): an rate of data package number of destination node received successfully and data package number sent out by source node in application layer;

(2) Average number of link failures: average number of link failures in the stage of route;

(3) Routing requests ratio: percent of routing requests that accounts for all routing requests;

(4) E2E (Average end to end delay): time difference of sending and receiving of data package received.

### 6.3. Simulation result

#### 6.3.1. Effect of variation of data transmission rate on routing performance



Figure 3 shows changing curve of packet transmission rate along with data transmission rate. Figure 3 indicated that EGRAODV proposed possesses the highest packet transmission rate compared to PBR and AODV. In addition, variation of EGRAODV along with data transmission rate is rather stable, however, PBR and AODV are reduced rapidly. This is mainly because EEGM model is adopted by EGRAODV to improve the stability of route. In the meantime, EGRAODV is not required to broadcast RREQ, which saves up network resources and provides more bandwidth for packet transmission rate.

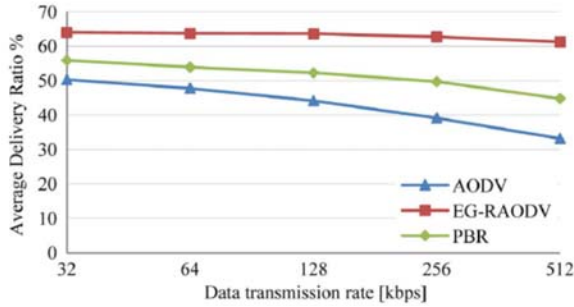

Fig. 3. Experiment A: variation of packet transmission rate along with data transmission rate

Figure 4 shows changing situation of routing requests ratio along with data transmission rate. Compared with PBR and AODV, the routing requests rate of EGRAODV is the smallest. This is mainly because PBR and ODV don't stop broadcasting RREQs until destination node, however, EGRAODV is only required to transmit according to MRJ and free of broadcast, which reduces the quantity of sending out RREQs.

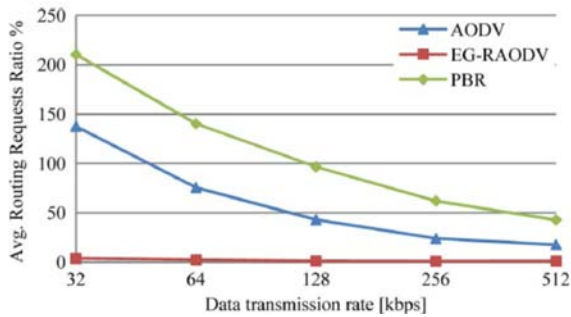

Fig. 4. Experiment A: variation of routing requests rate along with data transmission rate

Figure 5 shows changing situation of average number of link failures of EGRAODV, PDR and AODV along with data transmission rate. The figure indicated that EGRAODV has the minimum average number of link failures. AODV being the highest, this is because shortest patch principle is adopted by AODV to select route without considering link reliability. The reason why PDR is superior to AODA is

because prediction mechanism of link lifetime is adopted by PDR, a new route will be selected before the link is failed. Moreover, figure 5 reveals that the higher data transmission rate, the superiority of EGRAODV becomes more obvious.

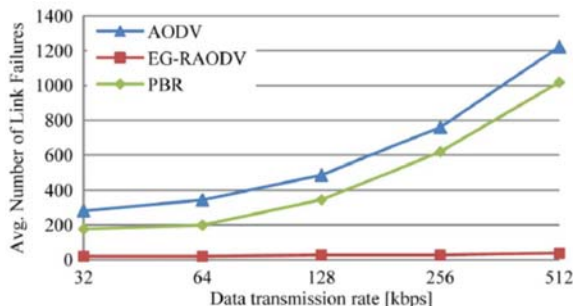

Fig. 5. Experiment 5: Variation of average number of link failures along with data transmission rate

Another advantage of EGRAODV proposed reflects on average end-to-end transmission delay as shown in figure 6. EGRAODV has the lowest end-to-end transmission delay. This is mainly because EGRAODV is provided with an entire EEGM message, which will easily predict the position of other nodes and find out the most reliable route. Owing to the route is established only using originally reactive routing method by AODV, thus end-to-end transmission delay of AODV being maximum.

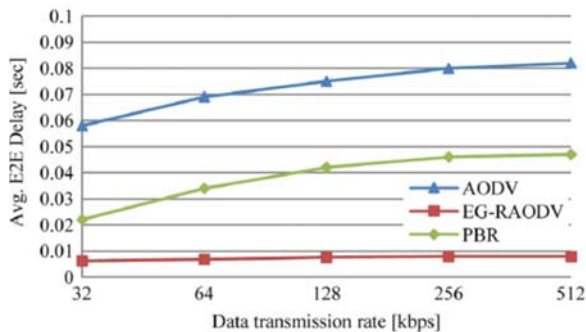

Fig. 6. Experiment A: Variation of average end-to-end transmission delay along with data transmission rate

### 6.3.2. Effect of variation of packet size on routing performance

#### Figure 7. Experiment B: Variation of packet transmission rate along with packet size

Variation of EGRAODV along with data packet size represents the highest packet transmission rate and it's very stable as shown in figure 7. Notice that large-sized data packet might be transmitted dispersedly. In packet transmission process, any

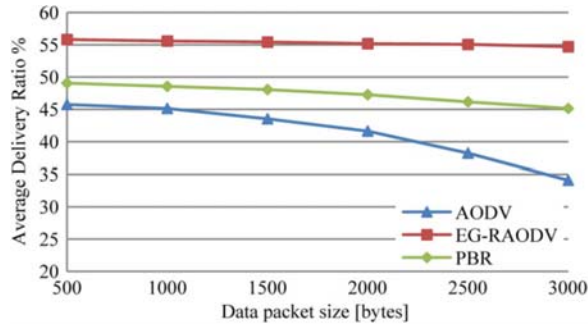

Fig. 7. Experiment B: Variation of packet transmission rate along with packet size

fracture of transmission disperse data packet link might lead to a failure to whole data packet transmission. If fails, it's required to start it over again. The figure indicated that the performance of EGRAODV is superior to AODV, this is mainly because all access to destination node are hunted by EGRAODV and the most reliable path will be selected as transmission channel of data.

## 7. Conclusion

The routing issue of WSN is analyzed in this article. First of all, it expands graph theory and EEGM model is proposed. In the meantime, EG-Dijkstra algorithm is proposed integrating Dijkstra algorithm, and such algorithm is introduced in EEGM to seek out the most reliable access MRJ. Ultimately, EGRAODV routing protocol is proposed starting from the reliability. A simulation is conducted aiming at highway scene and a comparison is made with PBR and AODV. Results indicate that EGRAODV proposed is higher than PBR and AODV in terms of routing requests ration, average end-to-end delay, number of link failures and packet delivery ratio. This is mainly because all access reliability value is calculated through EEGM model by EGRAODV, and the most reliable data access is selected to be route of data. Meanwhile, forwarding node in EGRAODV do not broadcast RREDD but do direction propagation, which helps save up more network resources.

## Acknowledgement

National key research and development plan (2017YFC0804603); Basic scientific research project of China Academy of Safety Science and Technology (2016JBKY15, 2016JBKY05, 2017JBKY05).

## References

- [1] Y. R. TSAI: *WSN04-5: Coverage-Preserving Routing Protocols for Randomly Dis-*

- tributed Wireless Sensor Networks*[J]. IEEE Transactions on Wireless Communications 6 (2007), No. 4, 1240–1245.
- [2] M. S. PAN, L. W. YEH, Y. A. CHEN, ET AL.: *A WSN-Based Intelligent Light Control System Considering User Activities and Profiles*[J]. IEEE Sensors Journal 8 (2008), No. 10, 1710–1721.
- [3] C. ALIPPI, R. CAMPLANI, C. GALPERTI, ET AL.: *A Robust, Adaptive, Solar-Powered WSN Framework for Aquatic Environmental Monitoring*[J]. IEEE Sensors Journal 11 (2011), No. 1, 45–55.
- [4] A. OSTFELD, J. G. UBER, E. SALOMONS, ET AL.: *The Battle of the Water Sensor Networks (BWSN): A Design Challenge for Engineers and Algorithms*[J]. Journal of Water Resources Planning & Management 134 (2008), No. 6, 556–568.
- [5] T. H. SHIN, S. CHIN, S. W. YOON, ET AL.: *A service-oriented integrated information framework for RFID/WSN-based intelligent construction supply chain management*[J]. Automation in Construction 20 (2011), No. 6, 706–715.
- [6] W. K. G. SEAH, A. E. ZHI, H. TAN: *Wireless Sensor Networks Powered by Ambient Energy Harvesting (WSN-HEAP) - Survey and Challenges*[C]// International Conference on Wireless Communication, Vehicular Technology, Information Theory and Aerospace & Electronic Systems Technology. Wireless Vitae (2009), 1–5.
- [7] Y. LIN, V. W. S. WONG: *WSN01-1: Frame Aggregation and Optimal Frame Size Adaptation for IEEE 802.11n WLANs*[C]// IEEE Global Telecommunications Conference. IEEE (2006), 1–6.
- [8] L. WANG, L. D. XU, Z. BI, ET AL.: *Data Cleaning for RFID and WSN Integration*[J]. IEEE Transactions on Industrial Informatics 10 (2014), No. 1, 408–418.
- [9] Q. CHI, H. YAN, C. ZHANG, ET AL.: *A Reconfigurable Smart Sensor Interface for Industrial WSN in IoT Environment*[J]. IEEE Transactions on Industrial Informatics 10 (2014), No. 2, 1417–1425.
- [10] L. FERNANDO, G. S. ANTONIO-JAVIER, G. S. FELIPE, ET AL.: *A Comprehensive approach to WSN-based ITS applications: a survey.*[J]. Sensors 11 (2011), No. 11, 10220–10265.
- [11] Z. LV, A. HALAWANI, S. FENG, ET AL.: *Multimodal hand and foot gesture interaction for handheld devices*[J]. ACM Transactions on Multimedia Computing, Communications, and Applications (TOMM) 11 (2014), 1s.
- [12] GENG, Y., CHEN, J., FU, R., BAO, G., AND PAHLAVAN, K.: *Enlighten Wearable Physiological Monitoring systems: On-Body RF Characteristics Based Human Motion Classification Using a Support Vector Machine* PP (2015), No. 99, 1–16.
- [13] Y. LIN, J. YANG, Z. LV, ET AL.: *A self-assessment stereo capture model applicable to the internet of things*[J]. Sensors 15 (2015), No. 8, 20925–20944.

Received May 7, 2017